

WOODBURNING STOVES SUPPLEMENTAL APPLICATION

Applicant Name:
Physical Address:

Policy Number:
 Primary Secondary Seasonal

GENERAL

- | | | | |
|---|---|--------|-------------|
| 1. Make: | Manufacturer: | Model: | Year Built: |
| 2. Style: | <input type="checkbox"/> Franklin <input type="checkbox"/> Pot <input type="checkbox"/> Parlor <input type="checkbox"/> Box <input type="checkbox"/> Other: | | |
| 3. Construction: | <input type="checkbox"/> Cast Iron <input type="checkbox"/> Steel <input type="checkbox"/> Other: | | |
| 4. Approved by: | <input type="checkbox"/> Underwriter's Laboratory <input type="checkbox"/> None <input type="checkbox"/> Other: | | |
| 5. Installed by: | <input type="checkbox"/> Owner <input type="checkbox"/> Contractor <input type="checkbox"/> Other: | | |
| 6. Inspected by: | <input type="checkbox"/> Municipal Bldg. Insp. <input type="checkbox"/> Fire Dept. <input type="checkbox"/> Other: | | |
| 7. Is stove free of cracks or broken parts? | <input type="checkbox"/> Yes <input type="checkbox"/> No | | |
| 8. Use of stove: | <input type="checkbox"/> Only source of heat <input type="checkbox"/> Suppl. Heat source <input type="checkbox"/> Other: | | |
| 9. Roof: | Type: | Age: | Condition: |

CLEARANCES

- | | | |
|---|------------------------------|-----------------------------|
| 1. Is stove located on non-combustible floor material? | <input type="checkbox"/> Yes | <input type="checkbox"/> No |
| 2. Does floor protection extend at least 18" from side, back and front? | <input type="checkbox"/> Yes | <input type="checkbox"/> No |
| 3. Is stove spaced at least 36" from any combustible material? | <input type="checkbox"/> Yes | <input type="checkbox"/> No |
| 4. Is there at least 18" between top of stove pipe and ceiling? | <input type="checkbox"/> Yes | <input type="checkbox"/> No |

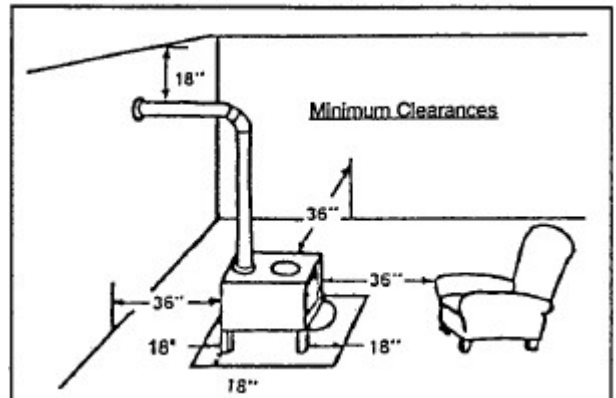

STOVE PIPE

- | | | |
|--|------------------------------|-----------------------------|
| 1. If stove pipe goes through wall or roof, Is a thimble installed? | <input type="checkbox"/> Yes | <input type="checkbox"/> No |
| 2. Does stove pipe fit snugly into thimble? | <input type="checkbox"/> Yes | <input type="checkbox"/> No |
| 3. Is stove pipe routed so as not to pass through floors, closets, concealed space or connect to chimney in attic? | <input type="checkbox"/> Yes | <input type="checkbox"/> No |
| 4. Does stove have an automatic draft regulator or built-in damper? | <input type="checkbox"/> Yes | <input type="checkbox"/> No |
| If not, does chimney have a damper Located near the stove? | <input type="checkbox"/> Yes | <input type="checkbox"/> No |

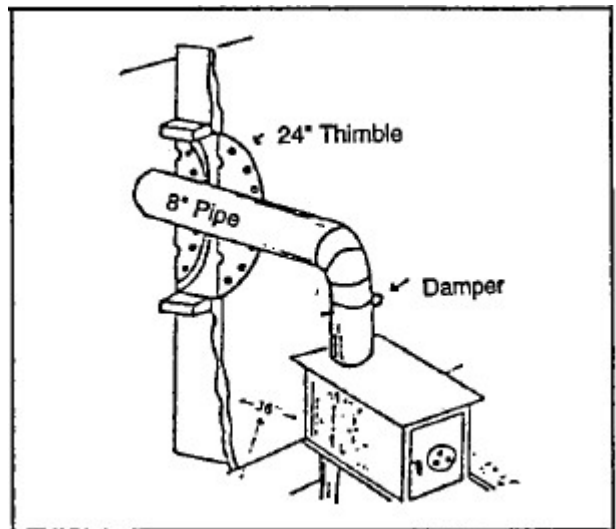

CHIMNEY

1. Was chimney professionally installed? Yes No
2. If a metal chimney, is it of approved, triple insulated type? Yes No
3. If an exterior metal chimney, is it installed with a clearance of at least 6" from walls of combustible construction and at least 24" from any door, window or walkway? Yes No
4. If a masonry chimney, is the flue tile and mortar in good condition? Yes No
 Also, is the termination height of the chimney at least 3' above the highest point where it passes through the roof and at least 2' above any portion of the building that is within 10' of the chimney? Yes No
5. Is the flue regularly inspected and cleaned to prevent creosote buildup? Yes No
6. Is there only one heating source for each flue? Yes No

